



# British Boots & Bonnetts Chronicle

Voice of the BBC

Volume 18  
Issue 10

Oct. 7, 2013

Editor  
Lynda Vickery

## President's Message

October 2013

Fall is here. You can tell by the nip in the air and the turning leaves. Time is running out to drive our British cars. So I hope you will take advantage of the remaining driving events on our schedule. There is a Springfield weekend drive along with several Drive and Dines. I hope to see you at one or all of these events.

A little Elf told me the BBB Christmas Party committee has come up with a great plan for a fun filled evening. So watch the Chronicle and your email for more information. There are less than 84 days to Christmas and even less to the Christmas Party. Time to start shopping for the gift exchange.

It is now time to begin seeking candidates for club officers. If you are interested in helping the club by serving as an officer, please give me a call or see me after a club meeting to discuss the opportunities available.

Larry Eils

*Words of Wisdom: Those who hesitate are not only lost, but miles from the exit.*



Next Meeting  
**Wed., Oct. 16, 2013**

Thunder Bay Grille  
7652 Potawatomi Trail  
Rockford, Illinois  
(near East State Street and  
Bell School Road)

**Dinner and social hour  
at 6:00pm  
Meeting begins at 7:00pm**

Once again our Club has had a very active month, and there were many great photos taken by our Events Chair, Rich Cannistra. There just isn't room in the Chronicle to publish them all. Hal Zenisek, Web Master, does post them all to our website. We invite you to visit the following link directly to the Events Photos to see them.

Editor, Lynda Vickery

[http://www.britishbootsandbonnets.com/BBB%20Website%20files/BBB\\_Events\\_2013.html](http://www.britishbootsandbonnets.com/BBB%20Website%20files/BBB_Events_2013.html)

## British Boots and Bonnets - Sept. 18, 2013 Membership Meeting Minutes

**President's Report:** President Larry Eils called the meeting to order at 7:00 with 44 members present. We had one guest: Thor Franks, grandson of Ron & Nancy Kuhnau. Larry asked that anyone interested in becoming an officer next year contact him as we're putting a ballot together.

**Vice President:** No report

**Secretary:** Minutes approved as in Chronicle.

**Treasurer:** Report given.

**Regalia:** All short sleeve shirts, 50% off, all jackets, 10% off. What's not sold tonight will go into raffle. We'll no longer carry a lot of stock. Instead, special orders will be taken.

**Chronicle/Newsletter:** Keep sending articles. If they are not used immediately, they will be used soon.

**Webmaster:** Thanks for pictures from events. Website will be updated. Special offer from man in Germany who started new company. MG watches for sale for about \$2200.

**Sunshine:** Wayne McKenna passed away. Rita Kindren's condition is improved.

**Events:** Aug. 25, Geneva Concourse--Doug Cameron reported really nice cars. Aug. 25-26, Milwaukee Masterpiece--David Brickman reported Saturday was club day. British cars were well represented. Sunday was by invitation only. Sept. 1, Club picnic at Liberty Farm, home of Ed and Luz Lehman. 20+ British cars, 60+ people attended. Thank you to Ed and Luz who again, as always provided hamburgers, brats, carriage rides, and door prizes. Sept. 5, Kandu Industries English dinner. 16 cars, 38 people, good meal, enjoyable time. Sept. 6-8, Elkhart Lake Vintage Festival. Sept. 8 Harper College--a lot of cars, good weather. Ken and Barb Olendzki took first place with his 2004 Lotus, her 2014 Jaguar F type. Sept. 11 Drive and Dine to Crandall's Restaurant in Hebron. 31 people were present to enjoy a spirited ride. Sept. 13-16 Kuhnau and Eils led 13 cars and 26 people to Door County. Chilly temps, but good time. If you'd like picture book, contact Marna Grosenick. Oct. 5, Fall Color Tour, in afternoon with a stop for dinner. Oct. 9 Drive and Dine to Northleaf Winery, Milton, WI, led by Jim and Lynda Vickery. Sandwiches and light food from menu followed by wine and chocolate pairing. Oct. 18-20 Springfield tour visiting Lincoln sites. Christmas party, 12 weeks from tonight. Bev Joyce, chairman, will host a planning meeting at her house Sept. 27 at 10:30. Sept. 27 Ladies Who Do Lunch at Olive Garden, 12:30 and Retired Gentlemen, Hanson's in Beloit. Sept. 21 Auto Cross at Rockford Speedway. Sept. 19 POW-MIA at Field of Honor, Loves Park, candlelight ceremony. Wayne McKenna was very active in organization.

**Marques:** MG Rick Hamaker reported annual convention at French Lick extends invitation to all BBB members, June 15-19, 2014. **Triumph:** No report. **Jaguar:** Rich Cannistra reported Sept. 21 WI Jaguar Club 30th anniversary at Milwaukee Zoo. **Austin Healey:** No report. **Lotus:** No report. **Rolls Royce:** No report. **Minis:** Larry Eils reported a 30th anniversary ride on IL highway 30.

**Classifieds:** Rick Hamaker - 1974 MGB-GT project car--make an offer. Rich Cannistra - 1984 Volvo 280 turbo and 1948 Plymouth 4-door custom special.

**Good Wrench Award:** Marv Proctor and Bob and Barb Buckavekas tied.

**Ed Eggleston Burnt Piston Award:** Dwayne Plymale

**Raffle:** Garage Chemicals to Ron Kuhnau, zip ties to Larry Eils, power washer hose attachment to Barb Buckavekas, Thunder Bay bucks to Solveig Maschke and Michelle Morey, Union Jack coffee mug to Brian Kobiaschka.

**Joke:** by Larry Eils.

**Adjournment:** 8:15

Respectfully submitted, Ginger Spaight



**Save the Date !!!**

***December 11, 2013***

***!!!Please note this is not the normal monthly meeting week!!!***

**Please come to eat, drink and be merry while celebrating the holiday season with the British Boots and Bonnets Car Club at our annual Christmas Party.**

**Lino's Restaurant in Rockford**

**6:00 pm - Registration and Cocktails**

**6:45 pm - Dinner, Program, Gift Exchange,  
British Door Prizes**

**More details and registration form in the  
November Chronicle.**

***(Reservations will be due November 29th.)***



## BRITISH CAR FESTIVAL

by Rich Cannistra

The Annual British Car Festival at Harper College near Palatine, IL once again provided an amazing display of beautiful British Iron. Weather conditions could not have been more perfect and six cars from the club were on display. Two of those also brought home People's Choice Awards for their effort: Barb Olendzki for her 2014 Jaguar F-Type and Ken Olendzki for his 2004 Lotus Esprit. Congratulations Ken and Barb!

If you did not make it to the show this year, mark your calendar for next time. The large number and variety of British rides each year make it well worth the effort.





## SEPTEMBER DRIVE AND DINE GOES TO THE CHICKENS

by Rich Cannistra

Crandall's Restaurant in Hebron, IL is the kind of place that knows how to serve up large quantities of delicious food in a timely manner. As such they have long been a club favorite and once again we were not disappointed.

Rich and Jackie Bartlett hosted the event, and led off with a nice drive through the country on a beautiful summer evening. Upon arriving at Crandall's, we were joined by several other club members bringing the total for the well attended function to 31.

Although known far and wide for their broasted chicken a variety of wonderful items were enjoyed by those present. Thank you Rich and Jackie for a great evening!





## DOOR COUNTY: BBBers HEADED NORTH FOR A BEAUTIFUL FALL WEEKEND

A Compilation by Rich & Roxann Cannistra, Marsha & Larry Eils, and Ron & Nancy Kuhnau

Talk of a long weekend in Door County, Wisconsin has been on the mind of several club members ever since the last great trip "up north". Ron and Nancy Kuhnau and Larry and Marsha Eils decided to do something about it, and in grand fashion for sure.

Friday September 13th proved lucky for 13 cars and 26 members who threw superstition to the wind to begin the journey. From the outset our hosts showed that meticulous planning had gone into the entire event. Maps, schedules and instructions were all perfectly arranged. Although the day was bright and sunny the temperature was certainly on the chilly side. This gave the polar bears of the group a chance to show their stuff with some top down driving in the brisk conditions.



The day's enjoyable travels found our group arriving at the Open Hearth Lodge in Sister Bay by late afternoon. Lodge owners Nora and John Zacek made all feel welcome and with a little time to unwind before dinner the magic of the weekend continued to unfold.



Dinner reservations at the Sister Bay Bowling Alley were perfect, as they lived up to their reputation of having the best food in the area - including the prime rib. The evening was concluded around a warm campfire with thoughts of the 13 cars sitting triumphantly in the parking lot, all having successfully stared down their bonnets at Friday the 13th.





Saturday dawned beautiful and after a quick breakfast it was off to the Maritime Museum in Gills Rock. The museum host, Wally, was very knowledgeable and we learned many interesting facts about great lakes, fishing, shipping, and of course the

ship wrecks and sinking of the Edmund Fitzgerald. We were even able to walk in a commercial fishing boat set up in the museum to experience what it was like fishing on the lake.



Following lunch at nearby Bay Shore Restaurant it was on to the water's edge. One group headed for the Cana Island Lighthouse. Built in 1869, this light has been in continuous operation since 1870, it's beam still a bright sentinel for those who brave Lake Michigan waters. Several hearty members climbed the 97 steps

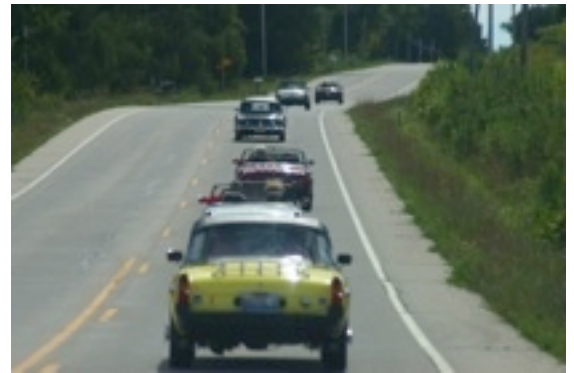

to the top for an incredible view. The visibility was unlimited so we could see Washington Island 26 miles away. A second contingent proceeded to Cave Point County Park. This scenic drive led to spectacular views of the rugged shoreline and lake.







Another scenic route along the peninsula's winding roads found us at the English Inn. The food was not only appropriate for our pseudo limey group, but the atmosphere easily transported one to a location near Abingdon or Coventry. A spectacular choice!

As if we had not packed enough memories into a beautiful day there was one more treat to come, "The Ghost Tour of Door County". As the sun set the stories rose as we wound our way from house to haunted house to mysterious occurrence to shipwreck to haunted lighthouse to graveyard. Yes, graveyard, somewhere back in the woods looking at headstones with torches (flashlights) wondering how we could have possibly thought that this was a sane idea. Fortunately the tour guide, Dracula (a.k.a. Russ), did find his way back to the mortal world where our LBCs were waiting to whisk us back to the lodge where most gathered in the Breakfast Room to toast the day's events.



Sunday morning brought rain as per the forecast (after all it was a British event), but it was short lived, and by noon the sun was peeking out. Everyone explored the county on their own until lunch time. Surprisingly, many of us met up at the Made in Britain store to purchase a variety of British items. Lunch at Bistro 42 followed by sampling of vodka and gin, and a large variety of different flavored olive oils at the Door County Distillery kicked the day into high gear.



The afternoon included a drive to the Simon Creek Vineyard for a taste of their products and music on the deck. A brief shower drowned out the music but by moving inside gave some members a chance to finish watching the Packer game; then go antiquing before meeting for dinner at the Greenwood Supper Club.



Hard as it was to believe, the weekend was almost over so plans for the Monday return trip were finalized along with reminiscing about the past three days of enjoyment. Due to real world constraints and individual schedules, members returned in several different groups. We did a special stop, at the request of a few mechanics, at a junk yard just in case they had any British cars: no luck. On occasion these old

British cars will act up and the return proved this by being slightly more troublesome as one couple completed the journey with their car on a flat bed truck. Memories of the great 4 day return to Door County will long be with us however. Larry and Marsha, Ron and Nancy...BRAVO! We had a fantastic time.





## WAYNE McKENNA

1946 - 2013

As the summer drew to a close, BBB members had to say farewell to an enthusiastic member of the club, Wayne McKenna. Although his health prevented him from participating recently, Wayne and his wife, Miki, were often seen at car shows, meetings, and other events. He enjoyed helping out with BBB car shows – assembling mailings at the Proctor's and showing his own cars, including taking home a trophy or two. He was always willing to give his time to the club, serving as Webmaster for nearly three years in order to ensure the club's presence on the internet.

Wayne died at home on September 16, 2013. He met his diagnosis of ALS with gratitude for his life, family and friends. He was a veteran of the Vietnam War, serving in the U.S. Marine Corps. In addition to BBB activities, his ethic of service to others led him to be active in the Rock Valley College Vets Club (past president), R.V.C. Easter Egg Hunt (former chairman), Viet NOW, National Association of Collegiate Veterans and Viet Nam Veterans of America. Wayne's volunteer service also included St. Bridget Catholic Church, Circle of Change, V.A. Boy Scout Leader with Troop 32, Lost Dogs of Illinois, Winnebago County Animal Service, and Beagle Rescue, Education and Welfare.

Wayne is survived by his wife, Miki; sons, Patrick and Scott; two brothers and several nieces and nephews. Wayne will be missed by all, and our heartfelt condolences go out to Miki and family.

by Connie Frazier





## OCTOBER DRIVE & DINE

### NORTHLEAF WINERY, MILTON, WI

by Lynda Vickery

You've heard about our next Drive & Dine: Wednesday, October 9th will be a trip to Northleaf Winery & Bistro in Milton, Wisconsin. We will start with dinner at the Bistro, located in a house across the parking lot from the winery. Then we will visit the winery and for those interested, take part in a wine and chocolate pairing which includes 6 different wine tastes and 6 different chocolates.

At the last meeting we collected money for those who planned to do the tasting, and we have enough members signed up to insure we can ask the winery to stay open for us. But, never fear, if you want to attend, just call and let us know so we have a count. And be prepared to pay \$10 per person when you get there. I will give the winery a list of those who have already paid, along with the money, so those who have paid, just check in. There should be regular wine tasting available, and their gift display is very nice.

The Bistro is very casual, and has a nice outdoor seating area, weather permitting. We will be able to order off their menu and pay separately.

Meet at the Roscoe Middle School by 5:15, for a departure time of 5:30. We should be at the winery by 6:30. If you plan to drive separately, just be sure to let us know, and we will see you there.

So, please call us 815-623-5611 with any questions, and to let us know you are coming if you didn't sign up at the meeting.

Thanks, Jim & Lynda Vickery

## LINCOLN'S SPRINGFIELD

### AWAITS YOU!

by Rick Hamaker

It isn't too late to make your decision to join your friends on a fascinating tour to Lincoln's Springfield. Our itinerary includes the following:

- ☒ A visit to the old state capitol where Lincoln kept an office.
- ☒ A tour of the renowned Lincoln Presidential Library.
- ☒ A tour of Lincoln's home.
- ☒ A visit to the newly renovated capitol building west wing, including the infamous copper doors.
- ☒ A driving tour of the countryside including part of old U.S. 66 hosted by a friend of BBB. (Time permitting.)
- ☒ An evening ghost walk.
- ☒ A visit to the historic New Salem Village.
- ☒ Plenty of great food and beverages.

The Springfield tour runs October 18-20. Call Rick or Sandy Hamaker for information on accommodations. Please join us!

#### Welcome New Members

New membership applications are available on the club's website. Register by sending your completed application to:

Connie Frazier, Treasurer  
**British Boots and Bonnets Car Club**  
5411 E. State Street, PMB 394  
Rockford, IL 61108  
[cfrazier9@yahoo.com](mailto:cfrazier9@yahoo.com)

Include \$20 annual membership dues plus a one-time fee of \$10 for name tags

## Webmaster Report for October 2013

by Hal Zenisek

Have you checked out the club's website recently? If not, look for the new pictures added to the member page, photos from various events this fall, or perhaps read the current or past newsletters. Our website is [www.britishbootsandbonnets.com](http://www.britishbootsandbonnets.com) in case you don't have it bookmarked as a favorite on your web browser.

The club received a couple interesting contacts via the website last month, however they were all sales and marketing oriented. Regardless, I wanted to share these with everyone. Maybe one of the following items will be of interest:

- From APT Instruments International...APT is the only distributor in the US who sells the entire line of **Smiths Instruments** which are made especially for British cars. Our website features a complete catalog with photos, descriptions and prices. We also service/repair Smiths gauges as well as other gauge brands (VDO, Stewart-Warner, AC Delco, etc.) and will provide technical support. Thank you for your attention. Marie at APT Instruments Intl Inc, 9632 Humboldt Ave S, Bloomington MN 55431, Phone: 952-881-7095, Website: [www.gaugeguys.com](http://www.gaugeguys.com).
- Dear friends of MG, Enthusiastic as I am about MG vehicles and having met the founder of the watch brand MeisterSinger, my decision to develop a high-quality mechanical **MG watch** and offer it to all friends of the brand matured during summer 2010. At the beginning of this year, my dream became true. I carry the series number 001 on my arm. From the beginning, the MG watch had been planned as a small series. In the meantime, my enthusiasm is shared by nearly 50 ardent MG fans, which has been achieved mainly by word-of-mouth recommendations. On the website <http://www.mg-watch.com> has pictures posted and describe the watch's impressive optic emulating a TD grill – including the MG octagon. Thank you for your kind support. Yours sincerely, Ernst Graaf [from Germany].
- Just a quick note to introduce myself. I'm Khristine at US Auto Parts, an online retailer of aftermarket auto parts and accessories. We're starting the USAP Insiders program to connect our brand with you, core enthusiasts that embrace our company's mantra of "*being the repair advocate for all vehicle owners, increasing their confidence in the repair process, and providing the most affordable option for their repair needs*". Pioneer members of the program will receive personal invites to review products from partners like K&N and Flowmaster, access to Insider only discounts, and preferred rewards status/commission tiers on our flagship websites. I'd love to share more details about the program. Let me know if you're interested. I look forward to hearing from you.---  
Khristine Angela Lleva | USAP Insiders  
[kalleva@usautoparts.com](mailto:kalleva@usautoparts.com)  
U.S. Auto Parts Network, Inc.  
16941 Keegan Avenue Carson, CA 90746  
<http://www.autopartswarehouse.com>  
<http://www.jcwhitney.com>

# Classic British Electric Basics Explained for the Novice

by Marv Proctor

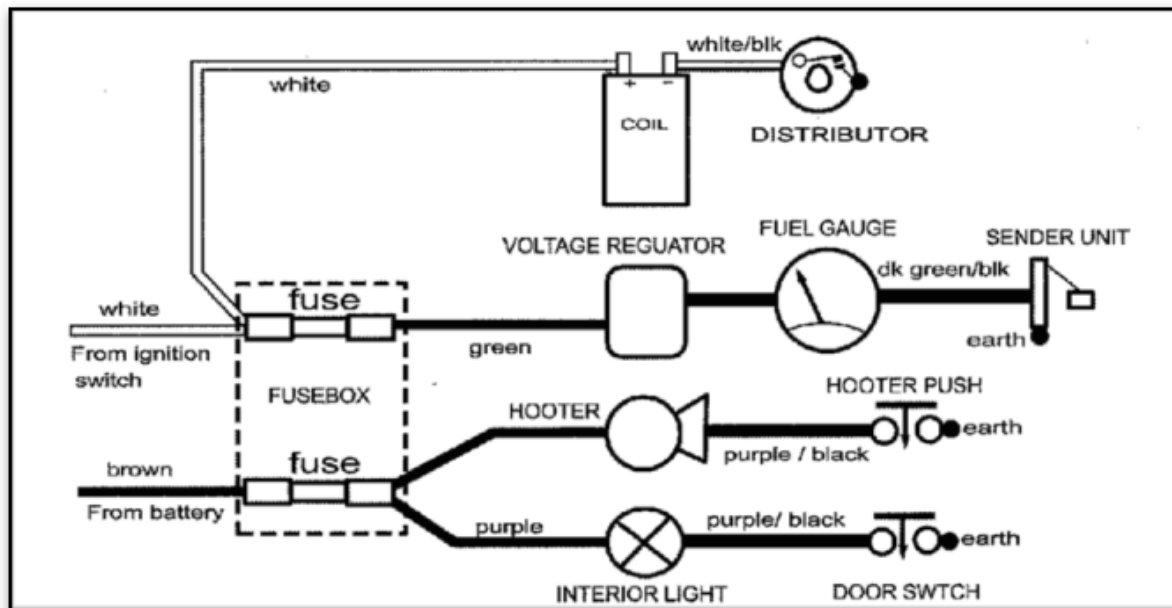

Preamble: The two primary wire colors that transmit power are white and brown.

A heavy gage white wire will almost always be switched power from the ignition switch and will then go to the fuse box before changing colors to downstream instrumentation and devices it is meant to control. The exception to this is illustrated in the sample diagram above where an un-fused white wire feeds the ignition circuit once the key is turned to the “on” position. The example above only illustrates a fused green wire feed off of the white wire ignition switch lead. (Other wire colors will generally follow the same pattern as this.) The solid green wire will run to the devices it is intended to power and control first and the wire exiting those devices will now be green with a black tracer that generally connects to a controlling switch mechanism that leads to an earthing (ground) connection as the fuel tank sending unit exemplifies in the illustration. The black tracer on any wire color indicates it is part of the “control” circuitry leading to an earthing connection. Solid colors will generally indicate they are fused power feeds to the device being controlled by that wire circuit. Black wires will typically be earthing (ground) connections to the other side of any controlling switch mechanism be it a dash switch, a fuel tank sending unit or an instrumentation light bulb.

A heavy gage brown wire will almost always be a power lead (always on) from the battery leading to the fuse box and then changing colors on the exit side of the fuse. The above example shows a solid purple wire going off to the “Hooter” (horns) circuit and the interior lights circuit. Notice again the solid purple color runs to the device(s) it is intended to control while the wire exiting those devices will now be the same color with a black tracer. This wire will lead to controlling switching mechanism(s) that take the device(s) to earth to complete their circuit(s) as with the discussion above on white wire.



In summation, the basics illustrated here are to show the reader a quick and simple method for helping him/her to troubleshoot typical British wiring found on our cars and bikes. Solid color wires (except brown and white) are generally carrying fused power to the device that it is intended to control. The same color wire with a black tracer will be the wire leading from the controlled device to a switching mechanism of some type. Solid black wiring will be a direct earth connection to the switching mechanism or illumination circuit.

As many of us know from first-hand experience having been the second, third or more generation owners of our vehicle, previous owner electrical "additions", "fixes" and "improvements" will not always, if ever, follow the wiring guidelines as set down by the manufacturers. Thus, "CAUTION" is the word of choice when troubleshooting wiring that has had previous owner "modifications" and it is the primary reason for using the caveat wording of "almost always" in the descriptions above.

DID-U-KNOW  
by Facia Nearside

In 1913 Riley named their latest car the 17/30. In 1920 AC had a model 12/24 and Alvis had the 10/30. Humber followed in 1930 with the model 16/50. Did English car makers simply have a lot of extra numbers laying around or were exciting names hard to think of?

Neither actually; it all has to do with collecting tax! At the beginning of the 20th century the British government asked the Royal Automobile Club to help devise a way to tax an automobile. In 1910 the RAC came up with the simple solution of multiplying the engine's piston diameter (or bore) by the number of cylinders. This extrapolated out to a crude approximation of horsepower and the car was taxed according to this value.

Technology quickly rendered this formula obsolete so auto makers flaunted the figures to show how little tax would be paid but how powerful their car really was. Thus a model 16/50 was taxed for 16hp but the engine actually produced 50hp. This archaic and inaccurate system remained in place until 1947.

America's Midwest Morgan Dealer  
**NORTHSHORE SPORTSCARS**

1225 Rockland Rd., Rte. 176,  
Lake Bluff, IL

847-247-0447 fax 0446

northshoresportscars.com

Specializing in services for all

**Classic British Automobiles**



Digital Printing Embroidery & Things  
**Stitches & Things**  
Quality with attention to detail

Your USA Connection to  
**JC Promotions**  
The Car Flag People



6516 North Deerpath Road  
Oregon, Ill. 61061  
Ph: (815) 234-8057

Loren "Jake" Jaquet "King of Things"  
Donna Jaquet "Queen of Stitches"

WWW.STITCHES-AND-THINGS.COM



**Premier Accounting & Tax, LLC**

Accounting, Income Tax, & Investment Specialists

**Beverly Joyce E.A.**

Accounting & Income Tax Specialist

127A Blackhawk Blvd  
South Beloit, IL 61080  
Phone: (815) 389-1165

7216 N. Alpine Road  
Loves Park, IL 61111  
Phone: (815) 633-9706

E-Mail: Bev@PremierAccounting.net



Yves P.G. Boode & Rich Range  
(815) 337-4001

**Vintage Sports Car, LLC**

1114 Rail Drive, Unit D  
Woodstock, IL 60098

email: Yves@vintagesportscar.net

websites: www.vintagesportscar.net • www.historicracecar.com  
Vintage Sports Car is a division of Historic Race Car, LLC

**Steve's British Connection  
CARS WANTED**

Very serious buyer for:

- Jaguar, XK-XKE,
- MG "T" series, MGA,
- Triumph TR-2-3-4-250
- Mercedes

`190-220-230-250-280 SL

All open cars, Porsche 356-911-914  
Austin Healey, Riley, Alfa Romeo, Singer,  
1964-1967. Ford Mustang, Model T.A.  
Entire Collections Possible. Any Condition,  
Any Location,  
Generous Finders Fee. 1930's—1960's.

**Steve Krantz**

sbcinc@aol.com or (630) 553-9023



PROPERTY  
**AJAX**  
INSPECTIONS  
Over 26 years experience.

RESIDENTIAL  
COMMERCIAL  
INDUSTRIAL

**ARCHIE J. MOREY**  
Licensed Inspector

1009 BRENTWOOD ROAD  
MACHESNEY PARK, IL 61115

**815.509.4975**  
ajzmg65@comcast.net

IL LICENSE#: 450-010304  
EXP: 11-30-2014

**British  
Marque**

**CAR CLUB NEWS**  
www.britishmarque.com

**BBB members:**

Subscribe to our print  
or on-line edition, get  
37% off the regular rate  
— and place **FREE**  
classified ads —  
for as long as you  
belong to the club!

**One year (11 issues), print: \$16** (regular price \$26)  
**One year (11 issues), on-line: \$12** (regular price \$19)

Go to our website today and download a free sample copy!  
Enthusiast Publications, LLC • 5 Old Nasonville Rd., Harrisville, RI 02830 • (401) 766-6920



**North American MGB Register**

Lynda Vickery, *Chronicles Editor*  
**British Boots & Bonnets Car Club**  
5549 Gray Eagle Road  
Roscoe, IL 61073

Mailing Label Here



Next Meeting  
**Wednesday, October 16, 2013**  
Thunder Bay Grille  
7652 Potawatomi Trail, Rockford, Illinois  
(near East State Street and Bell School Road),  
**Dinner and social hour at 6:00pm.**  
**Meeting begins at 7:00pm**